

JOB REPORT

8

ZX470-5G: Untuk Performa Konstruksi Pertambangan yang Efisien

ZX470-5G: For Efficient Mining Construction Performance

PRODUCT INFO

12

Aktivitas Konstruksi Lebih Produktif dengan Unit ZX350-5G

Increased Productivity in Construction with the ZX350-5G Unit

MINING INFO

17

EH3500AC-3: Solusi Andal untuk Industri Pertambangan

EH3500AC-3: Reliable Solutions for Mining Industry



MAGAZINE

ALAT BERAT

March 2023 - 15th Edition

Discover Your Equipment Needs



BELANJA KEBUTUHAN ALAT BERAT SEMAKIN MUDAH

Produk dan suku cadang resmi alat berat Hitachi
kini tersedia di berbagai *platform*

Temukan penawaran dengan harga terbaik.

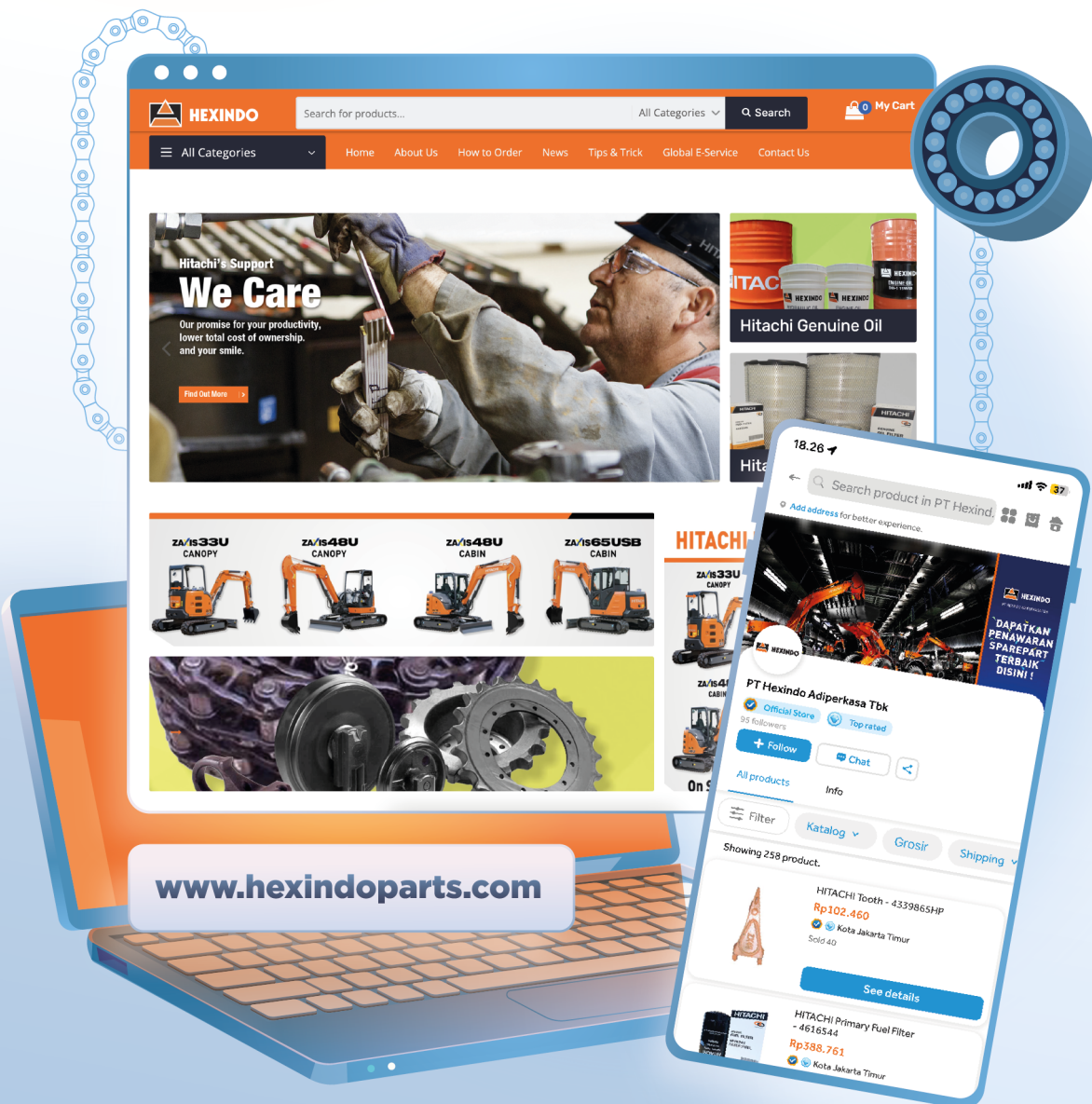

www.hexindoparts.com

Hitachi's Support We Care
Our promise for your productivity, lower total cost of ownership, and your smile.

Hitachi Genuine Oil

HITACHI

ZA/IS33U CANOPY **ZA/IS48U CANOPY** **ZA/IS48U CABIN** **ZA/IS65USB CABIN**

PT Hexindo Adiperkasa Tbk
Official Store | Top rated
95 followers

HITACHI Tooth - 4339865HP
Rp102.460
Kota Jakarta Timur
Solo 40

HITACHI Primary Fuel Filter - 4616544
Rp388.761
Kota Jakarta Timur



Bapak Dwi Swasono

Direktur Sales
PT Hexindo Adiperkasa Tbk

Para pelanggan yang terhormat,

Terima kasih atas kepercayaan Anda terhadap produk dan layanan PT Hexindo Adiperkasa Tbk. Berkat dukungan dan kerja sama dengan para pemangku kepentingan, Hexindo dapat terus percaya diri untuk mempertahankan performa positif dan melewati kondisi pandemi yang sebelumnya melanda tanah air. Tidak hanya itu, penghapusan PPKM (Pembatasan Kegiatan Masyarakat), diprediksi dapat meningkatkan aktivitas ekonomi, inisiatif pembangunan akan terus berlanjut, dan permintaan akan alat berat akan semakin meningkat di Indonesia.

Hexindo optimis bahwa performa perusahaan akan dapat terus ditingkatkan ke depannya. Sebelumnya hal ini telah dibuktikan terus meningkatnya angka penjualan unit yang dicapai Hexindo terlepas kondisi pandemi pada tahun sebelumnya.

Hexindo memahami kondisi bisnis di Indonesia yang semakin membutuhkan produk dan layanan alat berat berkualitas tinggi. Karena itu, Hexindo berupaya untuk senantiasa menjadikan kepuasan pelanggan sebagai prioritas utama.

Hexindo sudah memiliki beragam strategi untuk menghadapi kondisi bisnis saat ini. Di tahun ini, Hexindo optimis mampu memenuhi lebih banyak kebutuhan para pelanggan melalui komitmen Hexindo untuk menambah *product line* alat berat. Perusahaan melakukan diversifikasi bisnis tidak hanya fokus ke tambang, tetapi juga konstruksi, pertanian dan kehutanan. Hexindo menyediakan beragam unit yang dapat disesuaikan dengan kebutuhan. Tidak hanya itu, program *Rent to Buy* dan *Premium Used* dihadirkan sebagai upaya memberikan kemudahan bagi pelanggan.

Hexindo juga terus mengajak para pelanggan untuk memanfaatkan fitur ConSite serta sejumlah *attachment*, salah satunya Bradken. Jangkauan *part remanufacturing* pun diperluas tidak hanya bagi industri tambang tetapi juga alat berat untuk industri konstruksi.

Di tahun 2023 ini, Hexindo akan berupaya untuk tetap mempertahankan posisi sebagai salah perusahaan penyedia alat berat terdepan yang mampu terus berkontribusi bagi para pelanggan maupun kemajuan pembangunan di Indonesia. Hexindo percaya, dengan usaha dan kemampuan yang dimiliki, perusahaan akan mampu memberikan solusi akan setiap kebutuhan pelanggan. Selain itu, perusahaan juga siap menerima *feedback* dan menjawab setiap pertanyaan demi kepuasan seluruh pelanggan.

Dear Esteemed Customers,

Thank you for your trust in the products and services of PT Hexindo Adiperkasa Tbk. With the support and good relationship with all our stakeholders, Hexindo has confidence to maintain our positive performance and get through the pandemic conditions that previously hit the country. Furthermore, abolition of PPKM (Enforcement of Restrictions on Public Activities), predicted to enhance economic activities, development initiatives will continue, and demand for heavy equipment will increase in Indonesia.

Hexindo is optimistic that the company's performance will continue to improve in the future. Previously, this has been proven by the continuing increase in unit sales figures achieved by Hexindo despite the pandemic conditions in the previous year.

Hexindo understands the business conditions in Indonesia which increasingly require high quality of heavy equipment products and services. Hence, Hexindo always strives to make customer satisfaction a top priority.

Hexindo already has various strategies to deal with current business conditions. This year, Hexindo is optimistic that it will be able to meet more customer needs through Hexindo's commitment to add its heavy equipment product line. The company continues to diversify its business, not only focusing on mining, but also construction, agriculture and forestry. Hexindo provides a variety of units that can be tailored to your needs. Not only that, Rent to Buy and Premium Used programs is also one of the facilities offered to customers.

Hexindo continues to encourage customers to take advantage of the ConSite feature and we offer several unit attachments such as the Bradken. The range of remanufacturing parts has also been expanded not only for the mining industry but also for construction equipment.

In 2023, Hexindo will strive to maintain its position as one of the leading heavy equipment providers that is able to continue to contribute to customers and development progress in Indonesia. Hexindo believes, with its efforts and capabilities, the company will be able to provide solutions to every customer need. In addition, the company is also open to receiving feedbacks and answer any questions for the satisfaction of all customers.

ALATBERAT

March 2023 - 15th Edition
Discover Your Equipment Needs

3 TOP MANAGEMENT MESSAGE

4 TABLE OF CONTENTS

5 PHOTO NEWS

CEO HCM Group Bapak Kotaro Hirano Hadir ke Hexindo
CEO HCM Group Mr. Kotaro Hirano Visit to Hexindo

6 SPECIAL INFO

Hexindo Mengadakan *Corporate Strategy Meeting* untuk semester kedua FY2022
Hexindo Held Corporate Strategy Meeting for the second semester of FY2022

3 Rangkaian Webinar *Kenkijin Spirit* di November 2022
3 Webinar of Kenkijin Spirit in November 2022

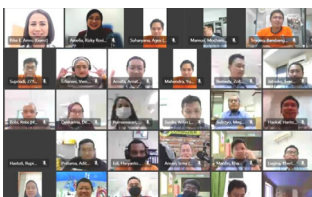

8 JOB REPORT

8 ZX470-5G: Untuk Performa Konstruksi Pertambangan yang Efisien
ZX470-5G: For Efficient Mining Construction Performance

10 Hitachi ZX210F-5G: Durabilitas dan Fleksibilitas di Segala Medan
Hitachi ZX210F-5G: Durability and Flexibility in all Terrains



12 PRODUCT INFO

Aktivitas Konstruksi Lebih Produktif dengan Unit ZX350-5G
Increased Productivity in Construction with the ZX350-5G Unit



14 SERVICE AND PARTS INFO

14 Hexindo PS Awards: Komitmen untuk Selalu Memberikan yang Terbaik
Hexindo PS Awards: A Commitment to Always Give the Best

16 Kinerja Lebih Baik dengan Komponen Pilihan: *Anti Rust Spring Adjuster*
Better Performance with Optional Component: Anti Rust Spring Adjuster

17 MINING INFO

EH3500AC-3: Solusi Andal untuk Industri Pertambangan
EH3500AC-3: Reliable Solutions for Mining Industry

20 OUR CUSTOMER

Persisten dan Investasi yang Tepat Jadi Kunci Sukses Bisnis
Perseverance and the Right Investments are The Key to Business Success

22 OUR BRANCH

Semangat Bekerja Sama dan Komitmen dari Cabang Jakarta untuk Memberikan Kontribusi yang Signifikan
The Spirit of Collaboration and Commitment from Jakarta Branch to Give Significant Contributions

24 CSR

24 Kontribusi Hexindo untuk Kelestarian Lingkungan
Hexindo's Contribution to Environmental Sustainability

25 *CSR Back to School: Kepedulian Hexindo untuk Dunia Pendidikan Indonesia*
CSR Back to School: Hexindo Contribution to Education in Indonesia

26 THE HIGHLIGHT

Hexindo Merayakan Ulang Tahun ke-34
Hexindo Celebrate 34th Anniversary

Majalah ini berada di bawah perlindungan hak cipta PT Hexindo Adiperkasa Tbk. Dilarang memperbanyak publikasi dalam bentuk apapun tanpa izin tertulis dari PT Hexindo Adiperkasa Tbk. Penerbit tidak bertanggung jawab atas segala kesalahan serta maksud dan tujuan dari seluruh konten yang ditulis oleh kontributor di majalah ini.

The Magazine is under copyright of PT Hexindo Adiperkasa Tbk. No part of the contents of publication can be reproduced in any form or by any means without a written permission from PT Hexindo Adiperkasa Tbk. The opinions expressed by the contributors are necessarily those of the publishers, who will not accept the responsibility for any errors or intentions.

CEO HCM Group Bapak Kotaro Hirano Hadir ke Hexindo

CEO HCM Group Mr. Kotaro Hirano Visit to Hexindo

Top Management dari Hitachi Construction Machinery (HCM) Group, Jepang yaitu Representative Executive Officer, President, Executive Officer, CEO Bapak Kotaro Hirano serta Executive Vice President and Executive Officer, CSO (Chief Strategy Officer) Bapak Naoyoshi Yamada mengunjungi PT Hexindo Adiperkasa Tbk pada Rabu, 5 Oktober 2022. Keduanya hadir untuk berdiskusi dengan jajaran Direktur, kepala cabang, kepala proyek serta manajerial perusahaan lainnya sekaligus menyampaikan inti strategi bisnis yaitu memperkuat rantai nilai (*value chain*) bisnis, menghadirkan berbagai solusi untuk setiap kebutuhan pelanggan serta pembentukan struktur perusahaan yang fleksibel.

Top management of Hitachi Construction Machinery (HCM) Group, Japan that is Representative Executive Officer, President, Executive Officer, CEO Mr. Kotaro Hirano and Executive Vice President and Executive Officer, CSO (Chief Strategy Officer) Mr. Naoyoshi Yamada visited PT Hexindo Adiperkasa Tbk on Wednesday, October 5, 2022. Both were present to discuss with Board of Directors, branch heads, project heads and other corporate managerial as well as explaining the core business strategy specifically strengthen value chain business, provide enhanced solutions at every contact with customers and form highly flexible corporate structure.



Bapak Kotaro Hirano (kemeja putih) bersama jajaran Direksi PT Hexindo Adiperkasa Tbk beserta jajaran manajerial perusahaan

Mr. Kotaro Hirano (in white shirt) with Board of Directors and managerial representatives of PT Hexindo Adiperkasa Tbk

Hexindo Mengadakan Corporate Strategy Meeting untuk Semester Kedua FY2022

Hexindo Held Corporate Strategy Meeting for the Second Semester of FY2022



PT Hexindo Adiperkasa Tbk menyelenggarakan *Corporate Strategy Meeting* untuk semester kedua FY2022 pada 11 November 2022 di Hotel Harris, Jakarta. Acara ini dihadiri oleh seluruh jajaran Direksi, kepala cabang, kepala proyek dan manajemen. Kegiatan ini menjadi wadah bagi manajemen puncak untuk memberikan arahan, mensosialisasikan kegiatan serta menyatakan target penjualan dan program kerja kepada jajaran manajemen.

PT Hexindo Adiperkasa Tbk held its *Corporate Strategy Meeting* for the second semester of FY2022 on 11 November 2022 in Harris Hotel, Jakarta. This event attended by Board of Directors, project heads, branch heads and management. Board of Directors give directions, socialize corporate event / campaign and state target sales as well as action plan to management.

3 Rangkaian Webinar Kenkijin Spirit di November 2022

3 Webinar of Kenkijin Spirit in November 2022

PT Hexindo Adiperkasa Tbk mengadakan 3 webinar dengan tema 'Live The Brand: Kenkijin Spirit' di bulan November 2022. Di webinar tersebut, perusahaan mengundang 3 pembicara dengan keahlian dan latar belakang profesional yang beragam untuk berbagi informasi dan pengalaman terkait 3 konsep *Kenkijin Spirit* yaitu Tantangan, Pelanggan dan Komunikasi. Pembicara tersebut diantaranya *General Manager of Supply Chain Management* PT Petrosea Tbk Bapak Sadewo Prasetyo (topik Tantangan), Dosen *Binus International University* Bapak Roozbeh Hendijani, PhD (topik Pelanggan) dan *CEO Communication Consultant* BeeComs Ibu Rike E. Amru (topik Komunikasi).

Webinar yang diadakan 1 kali dalam 1 minggu tersebut juga turut dihadiri oleh jajaran direksi diantaranya Presiden Direktur Bapak Djonggi Gultom, Direktur *Sales* Bapak Dwi Swasono dan Direktur *Business Development* Bapak Dai Tamura. Rangkaian webinar ini mendapat antusias yang cukup baik dari karyawan Hexindo yang tersebar di 52 kantor cabang, proyek maupun *contact office* di Indonesia. Sekitar 400 orang turut hadir di masing-masing webinar tersebut

PT Hexindo Adiperkasa Tbk held 3 webinars with the theme 'Live The Brand: Kenkijin Spirit' in November 2022. In these webinars, the company invited 3 speakers with diverse professional expertise and backgrounds to share information and experiences related to 3 concepts of *Kenkijin Spirit* namely Challenges, Customers and Communications. The speakers included *General Manager of Supply Chain Management* PT Petrosea Tbk Mr. Sadewo Prasetyo (Challenges topic), *Binus International University* Lecturer Mr. Roozbeh Hendijani, PhD (Customer topic) and *CEO of Communication Consultant* BeeComs Mrs. Rike E. Amru (Communication topic).

The webinar which was held 1 time per week was also attended by the Board of Directors including President Director Mr. Djonggi Gultom, Sales Director Mr. Dwi Swasono and Business Development Director Mr. Dai Tamura. We get high enthusiasm from Hexindo employees spread across 52 branches, projects and contact offices in Indonesia. About 400 people attended each of these webinars.

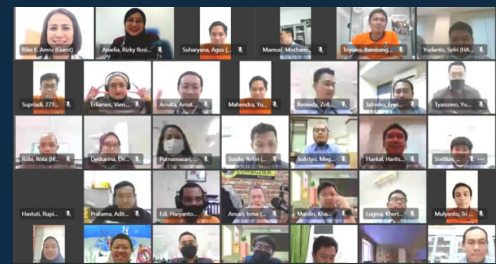



Customer Gathering untuk Wilayah Timur Indonesia

Customer Gathering for Eastern Indonesia Region

Mengawali tahun 2023, Hexindo menggelar *gathering* untuk para pelanggan Hexindo dari cabang di wilayah timur Indonesia di Harris Hotel and Convention Kelapa Gading, pada 11 Januari, 2023 lalu. Acara ini, berupa *gala dinner* untuk para pelanggan bersama dengan perwakilan dari Hexindo. *Gala dinner* ini dihadiri oleh Presiden Direktur Bapak Djonggi Gultom, Direktur Operasional Bapak Yasumasa Zaizen, Direktur Sales Bapak Dwi Swasono, sejumlah jajaran manajemen Hexindo, 3 orang perwakilan dari Hitachi Construction Machinery Indonesia (HCMI) serta 24 pelanggan Hexindo.

Selain untuk meningkatkan jalinan hubungan baik dengan para pelanggan, acara ini juga menjadi kesempatan Hexindo untuk berbagi tentang informasi terkini mengenai Perusahaan dan produk, salah satunya melalui presentasi mengenai *CPM package* oleh Kepala Departemen *Service Admin* Bapak Puji Nurwanto. Selain itu, perwakilan dari *customer* juga memberikan testimoni terhadap unit dan pelayanan dari Hexindo. Bapak Ariefuddin dari PT Sejahtera Dambaan Etam, Samarinda memberikan testimoni kepuasan terhadap *CPM package*. Bapak Pachrudin, sebagai salah satu *customer* mengungkapkan kepuasannya terhadap unit Hitachi. Dalam kesempatan ini, juga digelar penandatanganan *order letter* oleh beberapa *customer* yang tertarik dengan promo yang sebelumnya telah dipresentasikan oleh Wakil Kepala Divisi *General Sales Support*, Bapak Felix Simatupang.



At the beginning of 2023, Hexindo arranged a gathering for 24 customers, 3 Directors of PT Hexindo Adiperkasa Tbk area held in the Harris Hotel and Conventions, Kelapa Gading, on January 11, 2023. This event is held as a gala dinner for customers together with representatives from Hexindo. The gala dinner was attended by President Director Mr. Djonggi Gultom, Operations Director Mr. Yasumasa Zaizen, Sales Director Mr. Dwi Swasono, a number of Hexindo management, 3 representatives from Hitachi Construction Machinery Indonesia (HCMI) and 24 Hexindo customers.

In addition to nurturing good relations with customers, this event is also an opportunity for Hexindo to share update information about the Company and products, one of which was through a presentation on the CPM package by Service Admin Department Head Mr. Puji Nurwanto. Some representatives of customers also provided testimonials about the units and services from Hexindo. Mr. Ariefuddin from PT Sejahtera Dambaan Etam, Samarinda gave a testimonial on his satisfaction with the CPM package. In addition, Mr. Pachrudin, as one of the customers, expressed his satisfaction with the Hitachi unit. On this occasion, the signing of the order letter was also held by several customers who were interested in the promo which had previously been presented by Deputy General Sales Support Division Head, Mr. Felix Simatupang.

ZX470-5G: Untuk Performa Konstruksi Pertambangan yang Efisien

ZX470-5G: For Efficient Mining Construction Performance

ZX470-5G merupakan salah satu unit *hydraulic excavator* yang mengedepankan keandalan performa dengan mobilitas unit yang cepat, pengoperasian yang mudah, serta konsumsi bahan bakar rendah. Dengan berbagai keunggulan, ZX470-5G menjadi salah satu unit yang andal untuk kegiatan konstruksi di bidang pertambangan.

Salah satu perusahaan kontraktor pertambangan yang mengandalkan ZX470-5G dalam kegiatan operasi adalah **PT Bina Sarana Sukses**. PT Bina Sarana Sukses telah berkecimpung di industri konstruksi pertambangan selama bertahun-tahun. Core bisnis mereka meliputi; konstruksi pertambangan dan *hauling* batubara, di mana wilayah operasinya sebagian besar berada di Kalimantan maupun Sumatera, khususnya di area Muara Enim.

Meskipun masa pandemi menyebabkan ketidakstabilan di perusahaan di industri pertambangan, kinerja dan pencapaian PT Bina Sarana Sukses justru relatif stabil, bahkan mengalami pertumbuhan maksimal selama 2 tahun terakhir. Pertumbuhan ini merupakan hasil dari mematuhi himbauan pemerintah terkait penanganan Covid-19. Perusahaan pun berhasil mempertahankan kinerja yang baik berkat efisiensi bisnis yang diterapkan di level manajemen serta kemampuan mempertahankan relasi yang baik dengan para pelanggan PT Bina Sarana Sukses.

ZX470-5G is one of hydraulic excavators unit that provides reliable performance with swift unit mobility, easy operation and low fuel consumption. With its various advantages, the ZX470-5G becomes a reliable unit for construction activities in the mining sector.

One of the mining contractor companies that rely on the ZX470-5G in its operations is **PT Bina Sarana Sukses**. PT Bina Sarana Sukses has been a well known company in the mining construction industry for many years. The Company's core business includes; construction of coal mining and hauling, where most of the operational areas are located in Kalimantan and Sumatra, particularly in the area of Muara Enim

Although the pandemic caused instability for companies in the mining industry, the performance and achievement of PT Bina Sarana Sukses were relatively stable, even experienced maximum growth in the last 2 years. This growth is the result of complying with government regulations on overcoming Covid-19. The company also managed to maintain good performance thanks to business efficiency implemented at the management level and the ability to maintain good relationships with PT Bina Sarana Sukses customers.



Bapak Sulton Arafat
Head of Plant Department

Bapak Dwi Suwanto
Deputy Project Manager



PT Bina Sarana Sukses memiliki beragam unit alat berat untuk menunjang kegiatan operasi perusahaan. Salah satunya unit ZX470-5G dari Hexindo. Bapak Dwi Suwanto selaku *Deputy Project Manager* mengungkapkan, "Pertimbangan memilih unit ZX470-5G ini adalah layanan purna jual yang diberikan dan *lifetime unit* yang cukup baik, sehingga menunjang performa PA (*Physical Availability*) perusahaan."

"ZX470-5G merupakan unit spesialis kami untuk operasi di *pit-pit* kecil hingga *medium*, karena *spare part* mudah didapatkan dan fitur yang dimiliki membantu kegiatan operasi lebih efisien." Bapak Dwi Suwanto menambahkan.

Dari segi teknis, meliputi perawatan dan perbaikan alat, ZX470-5G sangat efisien untuk membantu kegiatan operasi perusahaan di Muara Enim, Sumatera Selatan. Dengan wilayah operasi mencapai hingga 20.000 titik, ketersediaan unit yang ada sangat menunjang performa operasi.

"Dibandingkan dengan unit lain di kelasnya, ZX470-5G tidak merepotkan, dan minim kerusakan. Dari segi *engine*, unit ini punya *power* yang baik, meskipun unit tergolong masih konvensional, tidak menjadi kendala selama pengoperasian di *site*." Bapak Sulton Arafat, Kepala Bagian Plant

Pertimbangan lain PT Bina Sarana Sukses memilih ZX470-5G adalah unit ini perawatannya termasuk dalam kategori *low cost*, sehingga lebih efisien. *Lifetime*-nya juga baik untuk membantu perencanaan berkala dan jangka panjang.

Terlebih lagi, Hexindo, sebagai perusahaan tunggal penyedia unit Hitachi ZX470-5G, memberi dukungan yang cukup membantu dari segi penyedia *spare part*. *Manpower* yang dimiliki juga sangat membantu dalam penanganan unit. Sehingga, secara keseluruhan, unit ZX470-5G dari Hexindo sangat membantu dalam performa operasional perusahaan.

PT Bina Sarana Sukses has a variety of heavy equipment units used to support the company's operations. One of them is the ZX470-5G unit from Hexindo. Mr. Dwi Suwanto as Deputy Project Manager said, "The consideration for choosing this ZX470-5G unit is the aftersales service provided and the unit lifetime which is quite good, so that it supports the company's PA (*Physical Availability*) performance."

"The ZX470-5G is our specialist unit for operations in small to medium pits, because spare parts are easy to find and the features help operations more efficiently." Mr. Dwi Suwanto added.

From a technical point of view, such as maintenance and repair of equipment, the ZX470-5G is very efficient in supporting the company's operations in Muara Enim, South Sumatra. With an operating area reaching up to 20,000 pits, the availability of existing units really supports operational performance.

"Compared to other units in its class, the ZX470-5G is hassle-free, and has minimal damage. In terms of the engine, this unit has good power, although the unit is considered as a conventional one, there is no issue during operation on the site." Mr. Sulton Arafat, Head Plant Division

Another consideration for PT Bina Sarana Sukses to choose the ZX470-5G is that this unit is categorised as a low cost unit, thus it is more efficient. It also has a good lifetime to support periodic and long term planning.

Moreover, Hexindo, as a sole distributor of Hitachi ZX470-5G unit, provides aftersale support to help in providing spare part. The manpower also assists well in unit handling. So, overall, the ZX470-5G unit from Hexindo is deemed really useful in supporting the company's operational performance.

Hitachi ZX210F-5G: Durabilitas dan Fleksibilitas di Segala Medan

Hitachi ZX210F-5G: Durability and Flexibility in all Terrains

Sebagai perusahaan yang bergerak di bidang konstruksi sipil, alat berat yang digunakan PT Lingga Indoteknik Utama (Lingga Group) membutuhkan daya tahan tinggi sehingga alat dapat digunakan dengan optimal.

Hitachi ZX210F-5G merupakan alat berat dengan durabilitas tinggi yang dirancang untuk penggunaan di medan berat dan sulit. Didesain dengan keunggulan di tiga aspek utama, yakni durabilitas, performa, dan *maintenance*, ZX210F-5G menjanjikan solusi komplit bagi perusahaan konstruksi sipil seperti Lingga Group yang beroperasi pada proyek jangka panjang yang mencakup hampir seluruh wilayah di Indonesia.

Didirikan pada tahun 2008, Lingga Group mengerjakan proyek konstruksi jangka panjang seperti pembangunan jalan tol, bendungan, pembukaan lahan sawit dan masih banyak lagi. Beberapa diantaranya bahkan proyek strategis milih pemerintah pusat maupun daerah. Proyek-proyek ini melibatkan pekerjaan konstruksi di medan-medan sulit seperti wilayah perbukitan berbatu serta pengerjaan timbunan untuk pembangunan bendungan.

Bapak Irwansyah Sinulingga selaku pemilik Lingga Group menyatakan bahwa pertimbangan utama perusahaan dalam memilih alat berat adalah kemampuan dan fleksibilitas alat untuk digunakan di berbagai medan, efisiensi penggunaan Bahan Bakar Minyak (BBM), perawatan dan nilai jual kembali unit Hitachi masih cukup tinggi.

As a company engaged in civil construction, the heavy equipments used by PT Lingga Indoteknik Utama (Lingga Group) require high versatility so that the machines can be used optimally.

Hitachi ZX210F-5G series is a high-durability machine designed for use in rough and difficult terrain. Designed with advantages in three main aspects, namely durability, performance and maintenance, the ZX210F-5G promises to be a complete solution for civil construction companies such as Lingga Group which operate on long-term projects in almost all regions in Indonesia.

Established in 2008, Lingga Group is a company that undertakes long-term construction projects such as the construction of toll roads, dams, clearing of oil palm land and many more. Some of them are even strategic projects chosen by the central and regional governments. These projects involve construction work in difficult terrains such as rocky hill areas as well as embankment work for the construction of dams.

Mr. Irwansyah Sinulingga as the owner of Lingga Group stated that the company's main considerations in choosing heavy equipments were the ability and flexibility of the equipment to be used in various fields, the efficiency of fuel (BBM) consumption, maintenance, and the equipment's resale value.

“Semenjak tahun 2012 Lingga Group memilih beralih dari penyewaan alat berat ke investasi alat berat Hitachi milik Hexindo dengan alasan alat berat Hitachi memiliki power yang lebih dibandingkan merk kompetitor sehingga dapat digunakan di medan-medan sulit, terutama medan berbatu. Selain itu juga keunggulan ketahanan mesin terhadap BBM lokal di area pengerjaan.”

“Since 2012, Lingga Group has chosen to switch from leasing heavy equipments to investing in Hexindo's Hitachi heavy equipments on the grounds that Hitachi's heavy equipment has more power than competing brands so that it can be used in difficult terrains, especially rocky terrain. Apart from that, it is also due to the superiority of the engine's resistance to local fuel on construction sites.”



Dari segi perawatan alat, Hitachi juga memiliki keunggulan karena perawatan yang relatif mudah, serta suku cadang yang gampang diperoleh dengan dukungan dari Hexindo.

Salah satu keunggulan lain yang dimiliki alat Hitachi dari segi suku cadang adalah fleksibilitas alat yang dapat digunakan secara manual apabila ada kerusakan pada suku cadang tertentu.

“Jadi, sambil menunggu *sparepart* didatangkan dari kota (pusat), pengerjaan proyek dapat terus berjalan.”

Tantangan yang dihadapi oleh Lingga Group, diantaranya dari sisi *cost control* proyek, dimana biaya proyek (50%-60%) didominasi oleh biaya alat berat, namun Bapak Irwansyah menyatakan bahwa keunggulan alat berat Hitachi dapat mengatasi permasalahan tersebut karena durabilitas mesin yang tinggi dapat meningkatkan *uptime* mesin sampai dengan 300 jam/bulan sehingga proyek dapat diselesaikan dengan lebih efisien dan tepat waktu.

Ke depannya Bapak Irwansyah berharap Hexindo dapat memberikan harga yang kompetitif serta fasilitas-fasilitas insentif keuangan yang memanjakan pelanggan seperti fasilitas uang muka, ataupun fasilitas kredit untuk suku cadang unit.

Selain itu, Beliau juga berharap agar hubungan baik Lingga Group dan Hexindo dapat terus terjalin dengan baik, yakni salah satunya dengan menyediakan dukungan layanan yang kooperatif dan responsif dimana pun dan kapan pun agar perusahaan dapat tetap bekerja sama ke depannya.

In terms of equipment maintenance, Hitachi also has the advantage of relatively easy maintenance, as well as easy-to-obtain spare parts with support from Hexindo.

One of the other advantages that Hitachi has in terms of spare parts is the flexibility of the tool which can be used manually without specific spare parts if any of these spare parts is damaged.

“So, while waiting for spare parts to be imported from the city, the company can still continue to work on projects.”

The challenges faced by Lingga Group, one of which is in terms of project cost control, where project costs (50%-60%) are dominated by heavy equipment costs. However, Mr. Irwansyah stated that the advantages of Hitachi's heavy equipments can overcome these problems because high machine durability can increase machine uptime of up to 300 hours/month so that projects can be completed more efficiently and timely.

In the future, Mr. Irwansyah hopes that Hexindo can provide competitive prices as well as financial incentive facilities that can pamper customers such as down payment facilities, or equipment spare parts credit facilities.

Lastly, he also hopes that the good relationship between Lingga Group and Hexindo can continue to be well-maintained, one of which is by providing cooperative and responsive service support wherever and whenever possible so that the companies can continue to work together in the future.





Aktivitas Konstruksi Lebih Produktif dengan Unit **ZX350-5G**

Increased Productivity in Construction with the ZX350-5G Unit

Sebagai salah satu unit terbaik Hitachi, ZX350-5G merupakan ekskavator medium yang handal untuk menunjang produktivitas selama kegiatan konstruksi, khususnya di medan yang berbatu dengan permukaan yang tidak rata. Unit ZX350-5G merupakan ekskavator dengan berbagai keunggulan guna meningkatkan efisiensi dan efektivitas sebagai sebuah ekskavator. Selain itu, konsumsi bahan bakar sedikit dan pergerakan *undercarriage* depan yang cepat juga berguna untuk meningkatkan efisiensi kerja.

Selain dilengkapi dengan peringatan *overload* dan *air condition*, jenis ekskavator *crawler* ini memiliki sistem Hidrolik HIOS III dan sistem kontrol *engine*. Sistem ini membantu meningkatkan kecepatan pengoperasian dengan konsumsi bahan bakar yang lebih sedikit. Terlebih lagi, unit seri ZX350-5G ini termasuk dalam kategori unit yang hemat bahan bakar, namun kecepatan penggalian dan pengoperasian tetap produktif.

The ZX350-5G is a reliable medium-sized excavator from Hitachi that is well-suited for use in construction activities, particularly in rocky terrains with uneven surfaces. It is known for its ability to support productivity on the job site. The ZX350-5G has a number of features that contribute to its efficiency and effectiveness as an excavator. Additionally, its low fuel consumption and fast front *undercarriage* movement can also help to increase work efficiency.

Besides being specially equipped with overload alert and air conditioning, this crawler excavator has HIOS III Hydraulic System and engine control. The system helps to increase operating speed with less fuel consumption. Moreover, ZX350-5G series is fuel-efficient, while keeping its digging speed and the operation productive.

Unit ZX350-5G dikenal memiliki ketahanan yang sangat tinggi, dengan *swing torque* yang cepat dan lincah, sehingga pekerjaan konstruksi dapat diselesaikan dengan waktu yang lebih efisien. Dengan dukungan sistem hidrolik HIOS III, pengoperasian unit ZX350-5G juga cukup mudah dengan sistem hidrolik pada unit, sementara pada bagian seat kemudi dalam kabin mengakomodir operator untuk mengoperasikan unit dengan lebih mudah dan nyaman.

Spesifikasi ekskavator Hitachi ZX350H-5G juga memiliki *bucket capacity* yang cukup besar sebesar 2.00 m³, sehingga dapat memaksimalkan alat berat ini saat menaikan muatan yang Anda perlukan, pekerjaan Anda menjadi lebih produktif dan dapat menghemat waktu.

Jenis ekskavator ini direkomendasikan untuk kegiatan penggalian di permukaan yang sangat berbatu atau medan sulit lainnya, karena didukung dengan sistem hidrolik dengan mode angkat daya otomatis yang secara otomatis juga meningkatkan gaya angkat dari *boom*. *Attachment* serta *boom* juga sangat kokoh dan tahan lama.

Produktivitas unit ini di kondisi yang sulit tidak perlu diragukan lagi. Ketahanan mesin dan kecepatan pengoperasiannya pun sudah teruji. Dengan konsumsi bahan bakar lebih sedikit dibandingkan unit lain di kelasnya, serta perawatan yang efisien, ZX350-5G merupakan unit terbaik yang membantu aktivitas kegiatan konstruksi jadi lebih produktif.

Walaupun hemat bahan bakar, tidak perlu ragu dengan performa dan kenyamanan dari ZX350-5G. Unit ini menggunakan mesin yang bandel ditenagai oleh Isuzu AH-6HK1X dan 6 silinder ini juga menggunakan *turbo charge*. Kabin dalam yang luas dan kursi pengemudi nyaman memberikan nilai tambahan dari sisi premium unit ZX350-5G.

Untuk mendapatkan informasi lebih lanjut mengenai bagaimana kami dapat memberikan nilai tambah bagi Anda melalui unit ZX350-5G yang hemat bahan bakar dan performa tinggi, silahkan hubungi cabang Hexindo terdekat.

The ZX350-5G is known for its high resilience, thanks to its swift and agile swing torque. This makes it well-suited for construction works, which can be completed efficiently with the use of this machine. The HIOS III hydraulic system of the ZX350-5G also makes operation easy, while the comfortable operator seat allows for easy and comfortable use.

The Hitachi ZX350H-5G excavator specifications also include a fairly large bucket capacity of 2.00 m³, which allows you to make the most of this powerful machine when lifting the necessary load and increase the productivity and efficiency of your work.

This excavator series is recommended for digging activities on very rocky surfaces or other difficult terrain, because it is supported by a hydraulic system with an automatic power lift mode which also automatically increases the lifting force of the boom. Its attachment and boom sections are also sturdy and durable.

When it comes to productivity in challenging conditions, the ZX350-5G stands out as a top choice. Its durability and operating speed have been tested and proven to be reliable. Its low fuel consumption and efficient maintenance make it a cost-effective option for construction activities. Overall, the ZX350-5G is a reliable and effective machine that helps to increase productivity in construction activities.

Despite being fuel-efficient, there is no reason to question the ZX350-5G's performance or comfort. This machine has a robust Isuzu AH-6HK1X engine with six cylinders and turbocharger. The comfortable driver's seat and roomy interior cabin add value to the ZX350-5G unit's premium side.

For further details on how we can improve your current operations with a low fuel consumption and high productivity ZX350-5G unit, please contact your nearest Hexindo branch.

Model:
Isuzu AH-6HK1X

Piston displacement:
7.790 L

Type:
4-cycle water-cooled, direct injection

Travel speeds:
High/Low : 0 to 4.9 km/h / 0 to 3.1 km/h

Number of cylinders:
6

Maximum traction force:
298 kN (30 400 kgf)

Rated power:
ISO 9249/ 184 kW (246 HP) at 2000 min-1 (rpm)

Gradeability:
70% (35 degree) continuous

Hexindo PS Awards: Komitmen untuk Selalu Memberikan yang Terbaik

Hexindo PS Awards: A Commitment to Always Give the Best

Sebagai perusahaan penyedia alat berat terkemuka di Indonesia, PT Hexindo Adiperkasa Tbk (Hexindo) senantiasa berupaya memberikan yang terbaik untuk pelanggan. Hexindo terus menjaga dan melakukan perbaikan kualitas produk dan pelayanan yang dimiliki salah satunya dengan rutin menggelar event *Product Support (PS) Awards* yang diberikan kepada anggota staf terbaik perusahaan.

Puncak acara *PS Awards 1st HY2022* diselenggarakan pada Kamis, 22 Desember 2022 di Lido Lake Resort by MNC Hotel yang dihadiri oleh sejumlah perwakilan dari manajemen, kantor cabang maupun proyek.

Acara dibuka dengan pidato pembukaan yang dibawakan oleh Direktur Operasional Bapak Yasumasa Zaizen serta *closing statement* oleh Direktur *Product Support* Bapak Teru Karahashi. Terdapat 29 kategori dengan total 68 pemenang *PS Awards* dari cabang dan proyek Hexindo di seluruh Indonesia. Untuk memastikan tingkat keakuratan dan objektivitas dalam penentuan pemenang *PS Awards*, penilaian pemenang setiap kategori diukur dengan parameter yang tertuang ke dalam aspek-aspek yang terkait kategori tersebut.



As a leading provider of heavy equipment in Indonesia, PT Hexindo Adiperkasa Tbk (Hexindo) always strive to provide the best for customers. Hexindo continue to maintain and improve the quality of its products and services, one of which is by regularly holding *Product Support (PS) Awards* event which are awarded to the company's best staff members.

The awarding event of the *PS Awards 1st HY2022* winners was held on Thursday, 22 December 2022 at Lido Lake Resort by MNC Hotel which was attended by a number of representatives from management, branch offices and projects.

The event was opened with an opening speech given by Director of Operations Mr. Yasumasa Zaizen and closing statement by Director of *Product Support* Mr. Teru Karahashi. There are 29 categories with a total of 68 *PS Awards* winners from Hexindo branches and projects throughout Indonesia. To ensure the level of accuracy and objectivity in determining the winner of the *PS Awards*, the assessment of the winner for each category is measured by the parameters contained in the aspects related to corresponding categories.



BRANCH WINNERS						
No	Competition/Award Name	Branch	Winner Name	Position	Branch	Remarks
1	Best Branch Warehousemen	Branch	Mughni H	Warehouse	Medan	1st
2	Best Branch Part Counter	Branch	Aldi Harry	Part Counter	Jambi	1st
3	AMT Performance Branch	Branch	Rakhmat	Section Head	Padang	1st
		Branch	Arif Nur Rohman	Planner, Section	Muara Enim	2nd
		Branch	Jamal	Section Head	Samarinda	3rd
4	Branch Service Admin	Branch	Sofianita Seffian	Admin Service	Jambi	1st
		Branch	Revi Hendiani	Admin Service	Jakarta	2nd
		Branch	Yenni Lestari	Admin Service	Samarinda	3rd
5	ConSite Shot	Branch	Andrie Dwi	Technician	Cilegon	1st
		Branch	Agus Sopyan	Technician	Jakarta	2nd
		Branch	Khoirudin Shob'ri	Technician	Muara Enim	3rd
6	SPE Performance	Branch	Supriyanto	CSS	Muara Enim	1st
		Branch	Jamal	CSS	Samarinda	2nd
		Branch	Rokhmadi Nur	CSF	Bandar Lampung	3rd
7	CPM Performance	Branch	Kaki Tanuji	Planner	Pontianak	1st
		Branch	Agus Tobroni	Planner	Samarinda	2nd
		Branch	Arif Nur Rohman	Planner	Muara Enim	3rd
8	Best ISF & Hexindo Parts	Branch	Aulia Rachman	Parts Counter	Samarinda	1st
		Branch	Adi Riswanoor	Parts Counter	Banjarماسin	2nd
		Branch	Somadi	CSF	Sungai Baung	3rd
9	Safety Performance - Branch	Branch	Andi Sunardi	CSS	Batulicin	1st
10	Branch Product Improvement	Branch	Widodo	CSS	Kaubun	1st
11	Branch Service Response	Branch	Parni	CSS	Surabaya	1st
12	Branch Part & Service Sales	Branch	Supriyanto	CSS	Muara Enim	1st
		Branch	Jamal	CSS	Samarinda	2nd
		Branch	Somadi	CSF	Sungai Baung	1st
		Branch	Ridwan	CSF	Banda Aceh	2nd
13	PSR Best Performance	Branch	Taufik Alamsyah	PSR	Muara Enim	1st
		Branch	Andi Afriandi Lubis	PSR	Samarinda	2nd
		Branch	Harmen Mulyadi	PSR	Pekanbaru	3rd
14	Branch PS Performance	Branch	Supriyanto	CSS	Muara Enim	1st



Muara Enim *Contact Office* berhasil memperoleh gelar *Best Performing Branch* dengan perolehan total 4 pemenang utama, 1 *runner-up*, dan 2 tempat ketiga, diikuti oleh Cabang Samarinda dengan perolehan 1 posisi pertama, 4 posisi kedua, dan 2 posisi ketiga. Cabang Jambi menempati posisi *branch* terbaik ketiga dengan perolehan 2 pemenang utama. Sedangkan untuk *Project Champions* dimenangkan oleh Hexindo Proyek Kideco dengan total 9 penghargaan, diikuti oleh Hexindo Proyek Sangatta dan Hexindo Proyek Balikpapan dengan masing-masing 4 penghargaan. Acara ditutup dengan *closing speech* oleh Bapak Teru Karahashi dan *Group Photo Session*. Untuk daftar lengkap pemenang *PS Awards 1st HY2022* dapat dilihat di bawah ini. Sekali lagi, Selamat untuk para pemenang!

The Muara Enim branch won the title of Best Performing Branch with a total of 4 first places, 1 runner-up and 2 third places, followed by the Samarinda Branch with 1 first place, 4 runner-ups and 2 third places. The Jambi branch is in the third best branch position with the acquisition of 2 main winners of the awards. Meanwhile, Hexindo Kideco Project won Project Champions with a total of 9 awards, followed by Hexindo Sangatta Project and Hexindo Balikpapan Project with 4 awards each. The event was closed with a closing speech by Mr. Teru Karahashi and Group Photo Session. For a complete list of PS Awards 1st HY2022 winners, see below. Once again, congratulations to all the winners!

PROJECT WINNERS						
No	Competition/Award Name	Branch	Winner Name	Position	Branch	Remarks
1	Best Project Warehouseman	Project	Abdurahman	Warehouse	Berau	1st
2	Best Project Part Counter	Project	Kamaruddin	Part Counter	Bengalon	1st
3	Best DIFFOT THIESS	Project	Mukti Donel	Part Counter	Sangatta	1st
4	AMT Performance Non FMC	Project	Julianto Firdaus	Planner	Samarinda	1st
		Project	Sulrahmi	Planner	Balikpapan	2nd
		Project	Doni Januar	Planner	Melak	3rd
5	AMT Performance FMC	Project	Nanang Gozali	Planner	Sangatta	1st
		Project	Fitriawan	Planner	Adaro	2nd
		Project	Ridwan Setiaji	Planner	Kideco	3rd
6	Post Inspection (PIR) Performance	Project	Wahyudi	Technician	Kideco	1st
		Project	Rafi Jati	Technician	Bengalon	2nd
		Project	Ahmad Nur	Technician	Samarinda	3rd
7	Safety Performance-Project	Project	Abdul Muhid	Project Head	Adaro	1st
		Project	Hiras Manurung	Project Head	Sumbawa	1st
8	Project PS Performance	Project	Sutoyo	Project Head	Kideco	1st
9	Project VHS Performance	Project	Ardian Eka	Part Counter	Berau	1st
		Project	Marjukin	Part Counter	Berau	2nd
		Project	Edi Haryanto	Part Counter	Sangatta	3rd
10	Part Specialist Performance	Project	Sanwani	Part Specialist	Sumbawa	1st
		Project	Muhammad	Part Specialist	Kideco	2nd
		Project	Asmar Amir	Part Specialist	Balikpapan	3rd
11	Project Part & Service Sales	Project	Djayadi	Project Head	Balikpapan	1st
		Project	Sutoyo	Project Head	Kideco	2nd
		Project	Riyanto Adi	Project Head	Luwe	3rd
12	Project Mpro & ConSite Report	Project	Kuswanto	Project Head	Toka Tindung	1st
		Project	Sutoyo	Project Head	Kideco	2nd
		Project	Djayadi	Project Head	Balikpapan	1st
13	Mining Technician Competition	Project	Rajiman Junaeni	Project Head	Muara Bungo	2nd
		Project	Abdul Latif	Technician	Muara Bungo	1st
		Project	Rahmat Hijrian	Technician	Kideco	2nd
		Project	Ivan Fauza	Technician	Kideco	3rd
		Project	Zulfikar Muttaqie	Technician	Kideco	4th
14	Best Mining Instructor	TC - Mining	Anton Sujarwo	Instructor	TC Balikpapan	1st
		Project	Jodi Rianto	Technician	Sangatta	1st
15	Best Training Participant	Project	Ihvan Arfendi	Technician	Sumbawa	2nd
		Project	Jupriyanto P	Technician	Melak	3rd

Kinerja Lebih Baik dengan Komponen Pilihan: Anti Rust Spring Adjuster

Better Performance with Optional Component: Anti Rust Spring Adjuster

Undercarriage menjadi bagian terpenting dalam sebuah ekskavator, yang berfungsi sebagai penggerak mesin di segala medan. *Undercarriage* dipersiapkan agar mampu bekerja di area dengan permukaan yang kasar atau tidak padat. Oleh karena itu bagian ini wajib mendapatkan pengecekan dan perawatan secara berkala, serta area pengoperasiannya juga perlu diperhatikan.

Pengoperasian unit di area seperti pinggir pantai, lahan gambut, ataupun air payau memiliki risiko korosi yang tinggi. Jika unit tidak dilindungi dari potensi timbulnya karat, maka dapat membuat komponen terdampak, termasuk *undercarriage* akan mengalami penurunan kinerja dan kualitas.

Salah satu komponen penting dalam *undercarriage* yang akan berdampak adalah *spring adjuster*. Adanya karat di bagian *spring adjuster* akan membuat *crawler* menjadi kaku. Selain itu karat yang muncul di spring adjuster akan menyebabkan retak dan kemudian patah.

Selain menyediakan unit yang telah siap pakai, Hexindo juga menghadirkan komponen pilihan. Saat ini unit yang diproduksi dari pabrik menggunakan spring standar, sehingga *customer* yang bekerja pada area dengan potensi korosi yang tinggi dapat menggantinya *Anti Rust Spring Adjuster*.

Anti Rust Spring Adjuster disarankan bagi pengguna yang mengoperasikan unit ZX200-5G di area dengan tingkat korosi tinggi seperti pinggir pantai, lahan gambut, ataupun air payau. *Spring Adjuster* juga bisa dipasang untuk unit ZX110MF-5G, ZX138MF-5G, seri unit ZX210, dan ZX350H-5G. Pemasangan *Anti Rust Spring Adjuster* pada *undercarriage* akan membantu memperpanjang masa penggunaan *Spring Adjuster*.

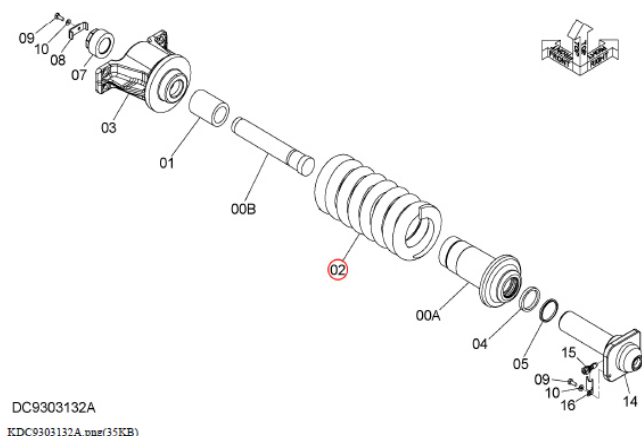

DC9303132A
KDC9303132A.ppt(35KB)



Undercarriage is one of the crucial parts in an excavator, which serves to move the machine over all types of terrain. The *undercarriage* is prepared for working in rough non-solid surface areas. Therefore, this part is required to get regular checks and maintenance, and its operating area needs to be assessed, as well.

Operating the unit in areas such as beach, peatland, or brackish water has a high risk of corrosion. If the unit is not protected from potential rust, this can make the components affected, including the *undercarriage* which will decrease in performance and quality.

One of crucial components in *undercarriage* that will be affected is the *spring adjuster*. The rust on the *spring adjuster* will make the *crawler* run stiffly. In addition, the rust in the *spring adjuster* will cause cracks then broken.

Besides providing ready-to-use units, Hexindo also offers optional components. Currently, units manufactured from the factory use standard springs, so customers who work in areas with high corrosion potential can replace that with the *Anti Rust Spring Adjuster*.

Anti Rust Spring Adjuster is recommended for customers who operate the ZX200-5G unit in areas with high corrosion rates such as beach, peatland, or brackish water. *Spring Adjuster* also can be installed ZX110MF-5G, ZX138MF-5G, series unit of ZX210, and ZX350H-5G. Installing the *Anti Rust Spring Adjuster* on the *undercarriage* will help extend the lifetime of the *Spring Adjuster*.



EH3500AC-3: Solusi Andal untuk Industri Pertambangan

EH3500AC-3: Reliable Solutions for Mining Industry

Dengan fitur terbaik di kelasnya, truk tambang EH3500AC dari Hitachi memberikan inovasi, produktivitas, kemudahan perawatan, dan operasi yang nyaman dan aman. Semua keunggulan tersebut memungkinkan biaya per ton bijih besi yang lebih rendah dan pengembalian investasi yang lebih besar bagi pelanggan global.

Proprietary drive technology kami yang terdapat di dalam truk tambang Hitachi EH3500AC-3 menghadirkan kinerja yang luar biasa dengan kecepatan yang lebih tinggi, kemampuan menanjak yang lebih baik, dan pengereman listrik yang dinamis serta lebih kokoh untuk operasi yang aman.

Equipped with multiple best in class features, the EH3500AC-3 series mining trucks from Hitachi offer superior innovation, productivity, ease of maintenance and safe comfortable operation. This overall provides a lower cost per ton of ore moved and greater return of investment to global customers.

At the heart of the Hitachi EH3500AC-3 is our proprietary drive technology providing superior mining truck performance with higher top speeds, better gradeability and stronger dynamic electric braking for safe operation.

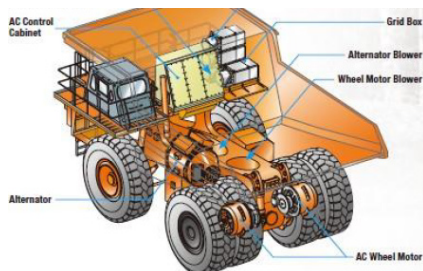

Sistem kontrol penggerak Hitachi terbaru memberikan stabilitas operasi dan kinerja optimal dengan menyesuaikan torsi motor roda proporsional secara otomatis untuk mengkompensasi beberapa kondisi operasi berikut:

The New Hitachi drive control system provides optimal operational stability and performance by automatically adjusting proportional wheel motor torque to compensate for any the following operational conditions:

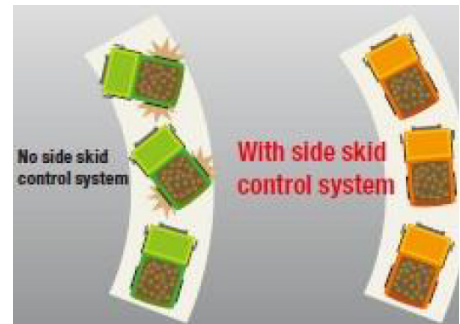
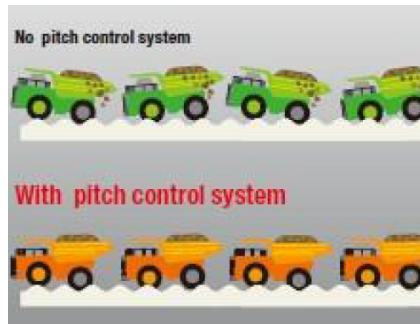
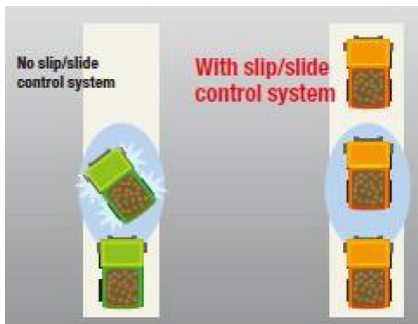

1. **Kontrol Slip Slide** - Jika sistem mendeteksi tergelincir atau roda belakang terkunci saat bepergian di kondisi jalan tambang licin atau beku, torsi motor roda secara otomatis disesuaikan secara proporsional untuk mempertahankan kontrol dan memberikan operasi yang aman dan stabil.

2. **Sistem Kontrol Pitch** - Jika sistem mendeteksi adanya kemiringan saat bepergian di jalan tambang yang buruk atau berhenti tiba-tiba, torsi motor roda disesuaikan untuk mengurangi kemiringan truk, sehingga menghasilkan kenyamanan operasi yang lebih baik dan mengurangi tumpahan muatan.

3. **Kontrol Side Skid** - Apabila sistem mendeteksi adanya *oversteer* atau *understeer*, maka torsi pada *Wheel Motor* akan secara otomatis diatur ulang untuk mengontrol *skid* samping yang terjadi. Dengan demikian, pengemudi dapat mempertahankan kendali yang stabil dan aman terhadap kendaraan pada kondisi yang sulit.

1. **Slip Slide control** - If the system senses slippage or locked of rear wheels when traveling in slippery or frozen haul road conditions, wheel motor torque is automatically adjusted proportionality to maintain control and provide safe, stable operation.

2. **Pitch Control System** - If the system senses pitching when traveling on poor haul roads or by stopping abruptly, wheel motor torque is adjusted accordingly to reduce pitching of the truck, resulting in better operating comfort and reduce load spillage.

3. **Side Skid Control** - If the system senses oversteer or understeer via wheel mounted sensors, Wheel Motor torque is again automatically adjusted accordingly to control the side skidding. In this way the operator can maintain stable & safe control of the vehicle in difficult conditions.

Selain itu, truk tambang Hitachi juga dilengkapi dengan beberapa fitur desain, inovasi, dan opsi keamanan terbaik di kelasnya seperti:

- *Auto Retarding Brake Control*
- *Auto Cruise Speed Control*
- Sistem kamera tampilan di sekitar mobil dengan *Aerial Angle*
- *Obstacle Detection System* dengan *Audible & Visual Alarms* baik dalam keadaan diam maupun bergerak
- Sistem kemudi dan rem darurat dengan ISO 5010 (SAE J1511) & ISO 3450 (SAE J1473)
- Kabin operator yang dibuat dengan HI-TECH dan sesuai dengan standar FOP-ROP, dilengkapi dengan fasilitas yang sangat nyaman, kelengkapan yang memudahkan penglihatan, serta sistem kontrol iklim yang sangat baik.
- Suspensi *trailing arm* dan NEOCON Strut yang dipatenkan oleh Hitachi memberikan kenyamanan berkendara yang superior serta kemampuan *cornering* yang baik.

Additionally, Hitachi mining trucks are fitted with some best-in-class design features, innovations & safety options, such as:

- *Auto Retarding Brake Control*
- *Auto Cruise Speed Control*
- *Aerial Angle surround camera system*
- *Obstacle Detection System with Audible & Visual Alarms* either while stationary or mobile
- *Emergency steering & braking systems ISO 5010 (SAE J1511) & ISO 3450 (SAE J1473)*
- A well-appointed HI-TECH, FOP's-ROP's compliant operators' cabin with excellent comfort, visibility & climate control.
- Hitachi patented trailing arm & NEOCON Strut suspension equally provides superior ride comfort and cornering capability.

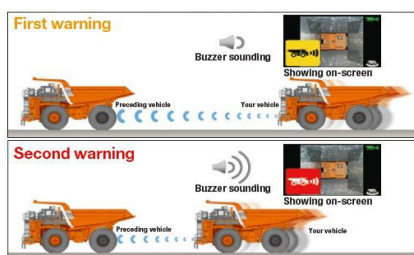

Obstacle Detection saat dalam posisi bergerak - mengurangi risiko tabrakan

Obstacle Detection while in Motion - reduces collision risk

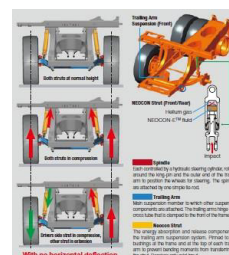

Suspensi Superior Hitachi yang menggabungkan *Swing Arm* dan *Strut NEOCON* yang dipatenkan.

Hitachi Superior Suspension incorporating *Swing Arm* & Patented NEOCON fluid ruts.

Serah Terima EH3500AC-3 kepada Kaltim Prima Coal

Handover of EH3500AC-3 to Kaltim Prima Coal

PT Kaltim Prima Coal (KPC), bagian dari PT Bumi Resources Tbk sekaligus Bakrie Group, merupakan perusahaan tambang batu bara terbesar di Indonesia.

Sebagai salah satu pelanggan terbesar Hexindo, KPC telah mengoperasikan lebih dari 100 unit peralatan pertambangan dari Hitachi Construction Machinery (HCM) termasuk ekskavator kelas 250T dan 350T, serta armada truk diesel listrik kelas 280T model EH4500AC dan EH5000AC yang lebih lama.

Berdasarkan rencana penggantian armada mekanis kelas 180T, Hexindo menjelaskan keunggulan efisiensi bahan bakar *dump truck* seri AC3 baru, stabilitas berkendara yang ditawarkan oleh Sistem Pengendalian Berkendara (*Hitachi Drive Control System*), serta keamanan tambahan dari sistem deteksi sudut aerial dan jarak dekat. Selain itu, truk seri EH3500AC-3 sudah menggunakan baterai dan sistem *trolley assist* untuk mendukung inisiatif KPC terkait pengurangan karbon di masa depan. Setelah meninjau secara kritis mengenai keunggulan Hitachi EH3500AC-3 dibandingkan dengan pesaingnya, termasuk kemampuan dukungan *on-site* dari Hexindo, keputusan akhirnya dibuat.

Mulai dengan pesanan 5 unit EH3500AC-3 pertama, Hexindo menerima tambahan permintaan 36 unit dan akhirnya berhasil mengantongi total pesanan 41 unit EH3500AC-3.

Tiga unit pertama telah berhasil dikirimkan ke KPC Sangatta pada November 2022 dan upacara penyerahan resmi dilakukan pada tanggal 23 November dengan tamu terhormat dengan tamu terhormat diantaranya VP Hitachi Construction Machinery (HCM) Group Bapak Tetsuya Hamabe, Chief Operating Office KPC Bapak Muhammad Rudy, GM Mining Operation Division KPC Bapak Hendro Ichwanto, dan GM Mining Support Division KPC Bapak Susilo Ari Wahyudi.

PT Kaltim Prima Coal (KPC), part of PT Bumi Resources Tbk as well as the Bakrie Group, is the largest coal mining company in Indonesia.

As one of Hexindo's biggest customers, KPC has operated more than 100 units of mining equipment from Hitachi Construction Machinery (HCM) including mining equipment, inclusive 250T & 350T class excavators plus substantial fleet of earlier model Hitachi EH4500AC and EH5000AC 280T class diesel electric trucks.

Based on the planned replacement of the existing 180t class mechanical fleet, Hexindo explained the fuel efficiency advantages of new AC3 series dump trucks, driving stability of the proprietary Hitachi Drive Control System, plus added safety of Aerial Angle & proximity detection system. In addition, the EH3500AC-3 series trucks remain battery ready & trolley assist capable for future KPC carbon reduction initiatives. KPC critically reviewed the Hitachi EH3500AC-3 advantages over competitors inclusive Hexindo on-site support capability and the decision was made.

Commencing initially with a 5-unit order of EH3500AC-3, Hexindo received an additional 36-unit inquiry and finally securing total order of 41 units of EH3500AC-3.

The first 3 units were successfully delivered to KPC Sangatta in Nov. 2022 and official handover ceremony conducted Nov. 23rd with honoured guests including VP Hitachi Construction Machinery (HCM) Group Mr. Tetsuya Hamabe, KPC Chief Operating Office Mr. Muhammad Rudy, KPC GM Mining Operation Division Mr. Hendro Ichwanto and KPC GM Mining Support Division Mr. Susilo Ari Wahyudi.



Highlight dari upacara penyerahan
Highlight of the ceremony





Bapak Hartono

Direktur Operasional
PT Tunas Jaya Perkasa

Persisten dan Investasi yang Tepat Jadi Kunci Sukses Bisnis

Perseverance and the Right Investments are The Key to Business Success

PT Tunas Jaya Perkasa merupakan salah satu perusahaan terpadang di industri alat berat yang bergerak di bidang rental alat berat dan kontraktor pertambangan. Dirintis sebagai perusahaan keluarga dengan nama CV Tunas Jaya, perusahaan awalnya bergerak di bidang penyediaan transportasi darat. Hingga pada tahun 1993, perusahaan mulai mengembangkan bisnis di bidang jasa rental alat berat untuk kebutuhan konstruksi, khususnya untuk perumahan dan proyek non-residensial lainnya. Ketika krisis ekonomi melanda pada tahun 1998, perusahaan melebarkan sayap dan mengembangkan bisnis di bidang pertambangan batubara, hingga sekarang.

PT Tunas Jaya Perkasa is a well-respected company in the heavy equipment industry, known for its equipment rental and mining contracting services. The company was founded as a family business, providing land transportation services under the name CV Tunas Jaya. In 1993, it expanded into heavy equipment rental for construction projects, especially residential and non-residential projects. When the economic crisis hit in 1998, the company further expanded and began to focus on the coal mining sector, where it continues to operate today.

Kami berusaha menjaga ritme perusahaan kami agar tidak terlalu larut dalam euphoria untuk berkembang pesat.

We try to keep our value by not investing too much on the euphoria to grow rapidly.

Salah satu alasan yang membuat PT Tunas Jaya Perkasa mampu berkembang dalam kondisi bisnis apapun adalah persistensi dalam menjalankan bisnis. Jika melihat perusahaan lain yang sering terjebak dalam pengambilan keputusan dengan cepat demi menyesuaikan dengan kondisi industri, PT Tunas Jaya punya cara yang berbeda. PT Tunas Jaya menganalisis kondisi bisnis dengan sangat rinci dan hati-hati dalam mengambil peluang yang tersedia.

PT Tunas Jaya Perkasa berkembang dengan strategi sendiri. Salah satunya, di tengah banyaknya pemain-pemain besar, perusahaan memilih untuk fokus ke sektor konstruksi pertambangan batubara di *size medium* yang lebih stabil. Dengan begitu, perusahaan mampu bertahan, bahkan menjadi kontraktor terbaik di pertambangan *medium size*.

Selain persistensi, PT Tunas Jaya Perkasa juga cenderung berinvestasi pada hal yang tepat, salah satunya sumber daya manusia. Perusahaan lebih memilih berinvestasi pada sumber daya manusia yang sedikit namun terbaik dan berkualitas, dibandingkan kuantitas.

Perusahaan berinvestasi tidak hanya pada sumber daya manusia, tetapi juga pada alat berat. Bapak Hartono mengungkapkan, "Dalam pemilihan alat berat, hanya satu pertimbangan kami: *cost per hour*. bukan hanya ditentukan dari *initial investment*, tapi juga di *lifetime* unitnya, *cost* untuk *repair* and *maintenance*, *fuel consumption*, dan cukup penting juga *use value* - nilai setelah selesai dipakai, dan kemudian bisa dijual dengan harga yang masih kompetitif."

One of the factors that has contributed to PT Tunas Jaya Perkasa's success in surviving through various business conditions is its perseverance in running the company. Unlike some other companies that may make impulsive decisions in an effort to adapt to industry conditions, PT Tunas Jaya Perkasa takes a more measured approach. The company carefully analyzes business conditions and looks for opportunities to grow.

PT Tunas Jaya Perkasa has their own way to grow. One of them, to stand out among many other big competitors, the company focus on medium-sized coal mining construction which tends to be more stable. By doing that, the Company is able to survive, even becoming the best contractor in medium size mining.

In addition to its commitment to persistence and careful investment, PT Tunas Jaya Perkasa also places a strong emphasis on hiring skilled and qualified professionals. This focus on quality over quantity has helped the company to build a reliable and competent team.

The company invests not only in human resources, but also in heavy equipment. Mr. Hartono stated, "In selecting heavy equipment, we only have one consideration: *cost per hour*. not only determined from the initial investment, but also in terms of the lifetime of the unit, the cost for repair and maintenance, fuel consumption, and quite importantly the *use value* - the value after finished using, and then can be sold with competitive price."



ZX350H-5G

Operating Weight: 32900 kg

Engine Rated Power: 184 kW (246 HP)

Backhoe Bucket: ISO Heaped : 2.00 m³

Unit yang paling banyak dimiliki PT Tunas Jaya Perkasa adalah ZX350H-5G yang merupakan ekskavator plus 30 ton. Menurut Bapak Hartono, unit ini memiliki *lifetime component* paling baik, dan termasuk unit yang terbaik di kelasnya.

Sejak tahun 2017, PT Tunas Jaya Perkasa telah mempercayakan Hexindo sebagai salah satu penyedia kebutuhan alat berat. Perusahaan mengakui bahwa alat berat dari Hexindo merupakan produk yang andal, memiliki *initial investment* kompetitif, serta sistem *delivery unit*-nya lebih pasti. Bapak Hartono juga mengungkapkan, "Dengan adanya *Hexa Finance*, salah satu dukungan pembiayaan, kami merasa terbantu, pelayanannya juga cukup baik, unitnya juga cukup baik. Semoga Hexindo bisa menjadi *market leader* dalam menyediakan alat berat untuk perusahaan pertambangan di Indonesia."

Kedepannya, Bapak Hartono, berharap Hexindo mampu terus memberikan pelayanan purna jual yang intensif serta memiliki program pelatihan berkelanjutan untuk para operator guna menjaga *lifetime unit*. Selain itu, juga diharapkan Hexindo menyediakan jasa ahli untuk menganalisis dan membantu perusahaan mengenali medan operasi, dan memberi rekomendasi unit mana yang bisa tepat sesuai area operasi.

The unit most owned by PT Tunas Jaya Perkasa is the ZX350H-5G which is an excavator plus 30 tons. According to Mr. Hartono, this unit has the best lifetime component, and is one of the best units in its class.

Since 2017, PT Tunas Jaya Perkasa has relied on Hexindo as one of its providers for heavy equipment. The company recognizes that Hexindo's products are reliable, have competitive initial investments, and have a dependable delivery system. Mr. Hartono also stated, "With Hexa Finance, as financing support, we feel helped, the service is also quite good, the units are also quite good. Hopefully Hexindo can become a market leader in providing heavy equipment for mining companies in Indonesia."

Moving forward, Mr. Hartono, hopes that Hexindo will continue to improve its after-sales service, provide ongoing operator training, and offer expert analysis and recommendations for heavy equipment units based on the specific needs and requirements of each company's operating area. This would help ensure that businesses have the right equipment to effectively meet the demands of their operations.

Semangat Bekerja Sama dan Komitmen dari Cabang Jakarta untuk Memberikan Kontribusi yang Signifikan

The Spirit of Collaboration and Commitment from Jakarta Branch to Give Significant Contributions

Setelah resmi ditunjuk oleh Hitachi sebagai agen tunggal *Excavator* merk Hitachi di Indonesia, Hexindo mendirikan cabang di Jakarta pada tahun 90-an. Cakupan wilayah operasional meliputi provinsi DKI Jakarta, provinsi Banten, dan sebagian kecil provinsi Jawa Barat, Hexindo Cabang Jakarta mengalami pertumbuhan yang sangat baik. Selama 5 tahun terakhir, cabang Jakarta memberikan kontribusi yang sangat signifikan, terutama dalam hal pencapaian penjualan.

Saat pandemi, Jakarta, menjadi salah satu provinsi dengan penyebaran virus Covid-19 paling besar di Indonesia. Hal itu menjadi tantangan terbesar karena keterbatasan waktu dalam pertemuan langsung antara cabang dengan para pelanggan dan mitra kerja.

Meskipun demikian, Hexindo Cabang Jakarta mempersiapkan timnya untuk tetap memenuhi harapan para pelanggan dan mitra kerja secara responsif dan tepat. Mereka telah dibekali pengetahuan dan pemahaman akan pentingnya menjaga kesehatan selama masa pandemi. Selain itu, Hexindo juga menjaga kekompakan tim dan turut menaati aturan kerja yang sebagaimana disyaratkan oleh Pemerintah selama masa pandemi agar selalu siap setiap saat untuk memberikan dukungan kepada para pelanggan.

Berada di Jakarta memberikan keuntungan tersendiri. Sebagaimana diketahui, Jakarta merupakan pusat industri dan bisnis di Indonesia yang memudahkan cabang Jakarta untuk mendapatkan peluang penjualan yang lebih besar dibandingkan cabang-cabang lain. "Di samping itu, letak kantor berada satu kompleks dengan kantor pusat. Dengan demikian, proses koordinasi dan komunikasi dengan departemen terkait di kantor pusat, menjadi lebih mudah dan cepat." Jelas Bapak Dedih Ifandi selaku Kepala Cabang Hexindo Jakarta.

After being officially appointed by Hitachi as the sole agent of excavators for the Hitachi brand in Indonesia, Hexindo established a branch in Jakarta in the 90s. The operational area covering DKI Jakarta province, Banten province, and some areas of West Java province, Hexindo's Jakarta branch experienced very good growth. Over the past 5 years, the Jakarta branch has made a very significant contribution, especially in terms of sales achievement.

During the pandemic, Jakarta was one of the provinces with the largest spread of the Covid-19 virus in Indonesia. This is the biggest challenge because of the limitations in face-to-face meetings between the branch and customers and work partners.

However, Hexindo Jakarta prepares its team to continue to meet the expectations of its customers and work partners responsively and precisely. The Hexindo Jakarta branch has been equipped with knowledge and understanding of the importance of maintaining health during a pandemic. Besides, Hexindo also maintains team work and complies with the work rules as required by the Government during the pandemic to always be ready at any time to provide support to customers.

Located in Jakarta provides distinct advantages for Hexindo Jakarta. As we know, Jakarta is the centre of industry and business in Indonesia, making it easier for the Jakarta branch to get bigger sales opportunities compared to other branches. "Other than that, the location of the Jakarta Branch office is in the same complex as the Head Office. Thus, the process of coordination and communication with related departments at the head office becomes easier and faster." explained Mr. Dedih Ifandi as Jakarta Branch Head.





Warehouse cabang Jakarta yang berada dibawah kewenangan kantor pusat menjadikan struktur organisasi cabang Jakarta tidak sekompleks cabang lainnya. Namun, cabang Jakarta tetap berupaya memberikan kontribusi untuk pemenuhan kebutuhan spare part bagi para pelanggan. Bapak Dedih menyebutkan, "Suatu saat di kemudian hari, Cabang Jakarta harus menjadi lebih besar dan lebih baik lagi, baik secara tim maupun fasilitasnya, mengingat cabang Jakarta akan menjadi barometer baik buruknya penilaian para pelanggan."

Pada tahun fiskal 2021, Hexindo Jakarta meraih penghargaan *nett income* terbesar pertama di antara seluruh cabang di Indonesia atau peraih kedua *nett income* terbesar kedua di antara seluruh cabang, dan proyek di Indonesia setelah Proyek KPC Sangatta. Sementara, di tahun fiskal 2022 di semester pertama, cabang Jakarta meraih penghargaan individu. Pada departemen Servis, meraih Servis Admin Terbaik kedua dan *Best Consite* Pertama. Selain itu pada departemen *unit sales* menjadi salah satu peraih penghargaan penjualan terbaik pada kurun waktu 2-3 tahun ke belakang.

Bapak Dedih menjelaskan bahwa faktor utama pencapaian tersebut karena dedikasi tim terhadap komitmen yang dipegangnya. Beliau mengungkapkan "Saya sangat bangga dan berterima kasih kepada semua tim yang telah memberikan kontribusi luar biasa kepada Perusahaan ini." Meskipun dalam situasi pandemi, cabang Jakarta sangat berantusias dan semangat menjaga kekompakan serta komitmen terhadap target-target yang telah ditetapkan oleh perusahaan.

Hexindo Jakarta juga aktif dalam memberikan gagasan, terobosan baru, dan pengembangan program yang sudah berjalan seperti, menambah model alat berat yang ditawarkan kepada pelanggan dan paket *best deal* baik pada *unit sales*, *service*, maupun *spare part*. "Kedepannya Hexindo harus menjadi sentra kebutuhan seluruh model alat berat dan pendukung – pendukung lainnya lebih baik lagi." tutup Bapak Dedih.

The Jakarta branch warehouse which is under the authority of the head office makes the organisational structure of the Jakarta branch not as complex as the other branches. Even so, the Jakarta branch is still trying to contribute to meeting the needs of spare parts for the customers. Mr. Dedih stated, "One day, the Jakarta Branch must become even bigger and better, in terms of team and facilities, considering that the Jakarta Branch will be a barometer of the good and bad ratings of customers."

In fiscal year 2021, Hexindo Jakarta won the first largest nett income award among all branches in Indonesia or the second largest nett income winner among all branches, and projects in Indonesia after the KPC Sangatta Project. Meanwhile, in the fiscal year 2022 in the first half, the Jakarta branch won the individual award. In the Service department, the Hexindo Jakarta branch won the 2nd Best Admin Service and the 1st Best Consite. In addition, the unit sales department has become one of the best sales award winners in the past 2-3 years.

Mr. Dedih explained that the main factor for this achievement was the team's dedication to the commitment. He said "I am very proud and grateful to all the team who have made extraordinary contributions to this Company." Even though in a pandemic situation, the Jakarta branch is very enthusiastic and passionate about maintaining teamwork and commitment to the targets set by the company.

Hexindo Jakarta is also active in providing ideas, new breakthroughs, and developing programs that are already underway, such as adding models of heavy equipment offered to customers and best deal packages for sales, service, and spare parts units. "In the future, Hexindo must become a centre for the needs of all models of heavy equipment and other supports even better." closed Mr. Dedih.



Kontribusi Hexindo untuk Kelestarian Lingkungan

Hexindo's Contribution to Environmental Sustainability

PT Hexindo Adiperkasa Tbk berkomitmen untuk berkontribusi kepada kelestarian lingkungan di Indonesia. Salah satunya melalui kegiatan CSR Lingkungan yang diadakan setiap tahun. Di 2022 ini, Hexindo mengadakan CSR *Back To Nature* dengan mendonasikan 330 bibit petai hibrida dan mengadakan program sosialisasi penanaman yang efektif kepada penduduk lokal selaku Mitra Binaan Hexindo di Cariu, Bogor, Jawa Barat. Diharapkan, penduduk sekitar tidak hanya mendapatkan manfaat berupa kelestarian lingkungan tetapi juga manfaat ekonomi melalui hasil penanaman tersebut. Di seremonial penyerahan bibit, perwakilan manajemen serta jajaran direksi diantaranya *Business Development Director* Bapak Dai Tamura dan *Product Support Director* Bapak Teru Karahashi melakukan penanaman pohon pinus di area hutan & konservasi rusa, Cariu, Bogor, Jawa Barat.

PT Hexindo Adiperkasa Tbk is committed to contribute in environmental sustainability in Indonesia. One of the corporate programs through Environmental CSR activities that conducted every year. In 2022, Hexindo held CSR *Back to Nature* by donating 330 seeds and conduct plantation program for local communities called 'Mitra Binaan Hexindo' in Cariu, Bogor, West Java. We hoped that people surrounded will not only get benefit from environmental sustainability but also economic benefits through the planting activity. At the ceremonial event, management representatives and Business Development Director Mr. Dai Tamura as well as Product Support Director Mr. Teru Karahashi planted pine trees in the forest & deer conservation area, Cariu, Bogor, West Java.



CSR Back to School: Kepedulian Hexindo untuk Dunia Pendidikan Indonesia

CSR Back to School: Hexindo Contribution to Education in Indonesia

PT Hexindo Adiperkasa Tbk berkomitmen untuk selalu berpartisipasi dan berkontribusi bagi kehidupan masyarakat di Indonesia. Tersebar di 52 kantor cabang dan proyek di Indonesia, Hexindo berperan aktif dalam kegiatan sosial dalam lingkup pendidikan, kesehatan, lingkungan dan isu-isu lainnya.

Salah satunya melalui CSR: Back To School yang terdiri dari 2 kegiatan yaitu Kelas Inspirasi dan Donasi Buku & Peralatan Basket yang diadakan di Balikpapan, Jakarta dan Manado. Melalui kegiatan ini, Hexindo menyumbangkan total 3400 buku kepada 10 sekolah yang tersebar di seluruh Indonesia.

Di Balikpapan, kegiatan Kelas Inspirasi dan Donasi Buku & Ring Basket diadakan di SD 012 Balikpapan Timur pada Kamis, 1 September 2022 dengan dihadiri oleh perwakilan manajemen Hexindo diantaranya Product Support Division Head Mr. Yuji Noguchi, Project Operation Division Head Bapak Elviansyah, Kepala Cabang Balikpapan Bapak Catur Riyadi, Corporate Secretary Ibu Listiana Kurniawati dan Kepala Departemen Finance Bapak Ilham Rachman. Kegiatan ini juga dihadiri oleh Senior Supervisor External Relation PT Thiess Contractor Indonesia Bapak Makmur dan Kepala Bidang Pendidikan Dasar Ibu Tri Yuniastuti, M.Pd.

Di kegiatan kelas inspirasi, perwakilan perusahaan, rekan kerja Hexindo dan pemerintah kota Balikpapan berbagi pengalaman dan cerita mengenai beragam jenis pekerjaan yang dapat menginspirasi sekitar 90 siswa kelas 6 SD 012 Balikpapan Timur. Diharapkan, siswa dapat semakin bersemangat menggapai mimpi dan cita-cita mereka.

PT Hexindo Adiperkasa Tbk committed to participate and contribute to Indonesian societies. Spread across 52 branch offices and projects in Indonesia, Hexindo plays an active role in social activities in education, health, environment and other issues.

One of them is through CSR: Back To School which consists of 2 activities, namely the Inspiration Class and Donation of Books & Basketball Equipment held in Balikpapan, Jakarta and Manado. Through this activity, Hexindo donated a total of 3400 books to 10 schools spread across Indonesia.

In Balikpapan, the Inspiration Class and Donation of Books & Basketball Equipment were held at SD 012 East Balikpapan on Thursday, September 1, 2022, attended by representatives of Hexindo management including Product Support Division Head Mr. Yuji Noguchi, Project Operation Division Head Mr. Elviansyah, Head of Balikpapan Branch Mr. Catur Riyadi, Corporate Secretary Mrs. Listiana Kurniawati and Head of the Finance Department Mr. Ilham Rachman. This activity was also attended by the Senior Supervisor External Relations of PT Thiess Contractor Indonesia, Mr. Makmur and the Head of Basic Education, Mrs. Tri Yuniastuti, M.Pd.

In the inspiration class, company representatives, Hexindo colleagues and the Balikpapan city government shared experiences and stories about various types of work that could inspire around 90 students of 6th grade in SD 012 East Balikpapan.





Hexindo Merayakan Ulang Tahun ke-34

Hexindo Celebrate 34th Anniversary

PT Hexindo Adiperkasa Tbk merayakan ulang tahun ke-34 yang bertepatan pada 28 November 2023. Seluruh cabang, *contact office* dan proyek yang tersebar di 52 wilayah di seluruh Indonesia merayakan hari ulang tahun tersebut dengan berbagai kegiatan diantaranya *family gathering*, *company outing*, dan lainnya. Ini merupakan salah satu wujud rasa syukur perusahaan telah berhasil melewati berbagai perubahan dan tantangan bisnis dengan baik. Bagi karyawan di kantor pusat dan cabang Jakarta, Hexindo merayakan ulang tahun di Ocean Dream Samudra, Ancol. Kegiatan dihadiri oleh seluruh jajaran Direktur diantaranya Presiden Direktur Bapak Djonggi TP Gultom, Direktur Operasional Bapak Yasumasa Zaizen, Direktur *Business Development* Bapak Dai Tamura, Direktur *Finance* Bapak Yoshendri, Direktur *Sales* Bapak Dwi Swasono dan Direktur *Product Support* Bapak Teru Karahashi.

PT Hexindo Adiperkasa Tbk celebrates its 34th Anniversary which coincides on 28 November 2023. All branches, *contact offices* and projects spread across 52 regions throughout Indonesia celebrate the anniversary with various activities including *family gatherings*, *company outings* and others. This is a form of gratitude for the company that successfully going through on business changes and challenges. For employees in Head Office and Jakarta branch, Hexindo celebrated its anniversary at Ocean Dream Samudra, Ancol. The activity was attended by Board of Directors that is President Director Mr. Djonggi TP Gultom, Operational Director Mr. Yasumasa Zaizen, Business Development Director Mr. Dai Tamura, Finance Director Mr. Yoshendri, Sales Director Mr. Dwi Swasono and Product Support Director Mr. Teru Karahashi.



HEXINDO SEDIAKAN FASILITAS ZAXIS REMAN COMPONENT

PT Hexindo Adiperkasa Tbk bekerja sama dengan PT Hitachi Construction Machinery Indonesia (HCM I) menawarkan *component rebuilt* dengan kualitas setara dengan komponen baru, bergaransi pabrik dan harga terjangkau. Hexindo siap selalu mendukung performa mesin *excavator* Hitachi lebih optimal.

Excavator Zaxis Class 10T-80T
diproduksi di *Remanufacturing Facility* di HCM I

Excavator Class 120T-550T
dan **Dump Truck** diproduksi di Reman Balikpapan

Bagaimana Cara Mendapatkan Komponen Reman Zaxis?

1. Pastikan ketersediaan komponen *old core* lengkap sesuai *part catalog* dan belum dilakukan pembongkaran
2. Hubungi cabang Hexindo terdekat untuk ketersediaan stok komponen Reman Zaxis dan proses pengembalian komponen *old core*
3. Kembalikan komponen *old core* kepada kami dalam periode maksimal satu bulan

PT Hexindo Adiperkasa Tbk

Kawasan Industri Pulo Gadung
Jl. Pulo Kambing II Kav. I - II No. 33, Jakarta 13930
Telp. 021-4611688 Fax.021-4611686
www.hexindo-tbk.co.id



HEXINDO